

Position	Amount	Type number	Description	PG
1	1	0100014025	MOTOR, CIRCULAR SAW BENCH 7,40 DNB BW 75	68
2	1	1380407686	BLADE COLLAR, OUTER RD 140 SCHWARZ RAL 9	31
3	1	6301047329	SPRING LOCK WASHER B 20 VERZ.	10
4	1	6200046208	HEXAGON NUT M 20X1,5 VERZ.	12
5	2	7008144944	HANDLE BAR SLEEVE RD 18X100	17
6	2	1001144959	HANDLE BAR	27
7	1	1010681681	BENCH STAND BW 750 GEPULVERT	61
8	2	7001017769	STARKNOB SCREW RD40/M6X23 (DIN 933) VERZ	12
9	4	6264139374	CAGE NUT M 8 BLECHSTÄRKE 1,8-3,2	12
10	2	1382407462	BRACKET, SAW GUARD BL 2,99X88X260	25
11	32	6103001178	Hex head screw	10
12	10	141151340	Washer	10
14	28	6209110995	Flange nut	10
15	1	1382407446	FLANGE GUARD BL 1,50X170X190	21
16	1	1492102829	Key	20
17	2	6171025867	HEXAGON HEAD TAPPING SCREW B 5,5X13 VERZ	10
19	1	1380407678	BLADE COLLAR, INNER RD 140	33
20	1	6721046182	FEATHER KEY A 8X5X36	10
22	4	141110640	Fillister head screw	12
23	4	6304084047	Serrated lock washer	10
25	1	1381663708	FAN WING 180X16 ET	27
26	1	1382663710	FAN COVER Ø 192 ET	29
27	1	8132719560	SWITCH SSK UC400V M=9,5A PHW K3000B/ST6/	58
28	1	1332036064	SWITCH PLATE BL 1,5X108X216 Z-FÖRMIG	17
31	4	6103001232	HEXAGON HEAD SCREW M 10X30 VERZ.	10
32	4	6209675984	FLANGE NUT M 10 VERZ./VERZÄHNUNGS-AUF	10
33	1	1382407403	MOTOR MOUNTING BRACKET BL 2,99X347X720	35
36	2	1382407667	WHEEL SET MOUNTING BRACKET BL 2,99X220X1	22
38	2	7270033053	WHEEL, PLASTIC RD 250 NABE 20,6+0,4	27
39	4	6300087696	MEDIUM WASHER	10
40	1	1010407601	FRAME, WHEEL SET	38
41	4	141114860	Hexagon head screw	12
42	2	6410007132	SHAFT COLLAR A 20,5 VERZ.	17
43	8	6103001127	Hex head screw	10
44	2	1482407753	ROCKER RETAINER BL 2,00X33X80	12
45	4	6209114230	Flange nut	10
46	2	1482407486	ANGLE BRACKET, ROCKER BEARING BL 2,99X14	15
47	8	6403681731	SERRATED EDGE WASHER ZA 16	10
48	1	1381680386	KERF PLATE, PLASTIC BW750	30
49	2	6103122986	HEXAGON HEAD SCREW M 8X85 VERZ.	12
57	4	1482407702	BRACKET, ROCKER LIMITOR FL 20X4X130	15

59	6	141150130	Washer	10
60	2	7058028481	RUBBER-METAL ANTI-VIBR. MOUNT	14
61	1	7051407690	TENSION SPRING RD 2,5X20X205	26
62	1	1382407470	BRACKET, TENSION SPRING BL 2,99X192X49	27
63	1	1010681754	ROCKER BW 750 GEPULVERT	61

toolspareparts.com.au

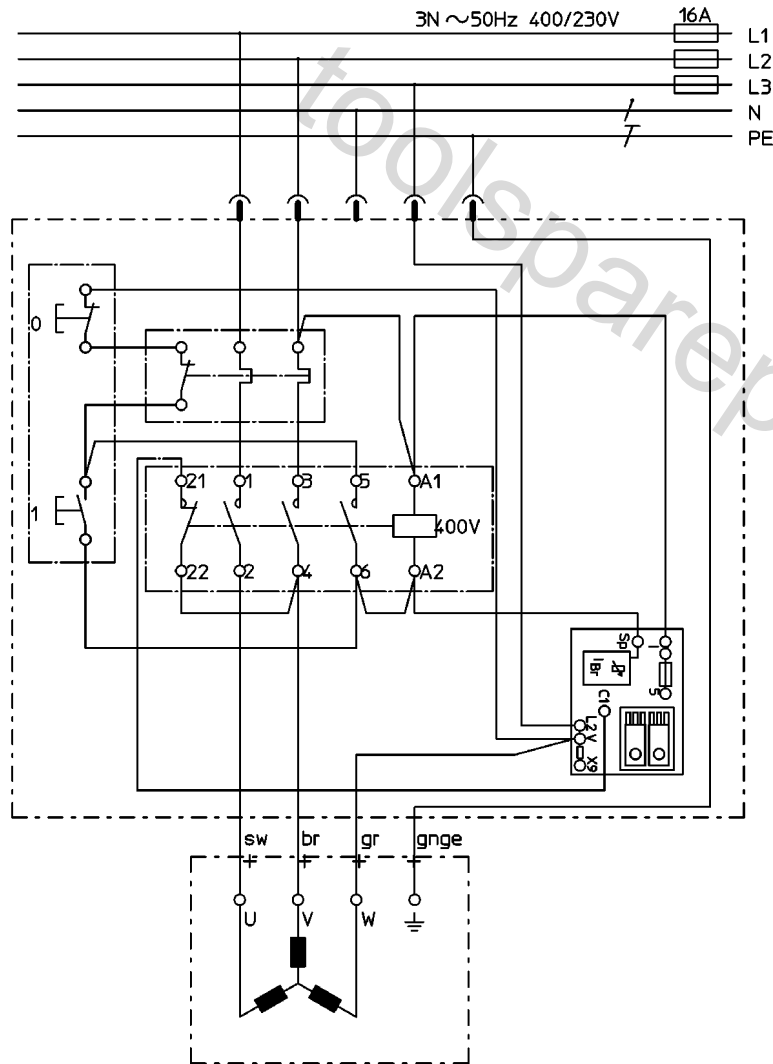

	Litzenfarben	Colour of strands	Couleur des cordons
BK	schwarz	black	noir
WH	weiß	white	blanc
BU	blau	blue	bleu
YE	gelb	yellow	jaune
RD	rot	red	rouge
TR	transparent	transparent	transparent
BN	braun	brown	brun
GY	grau	grey	gris
GNYE	grün-gelb	green-yellow	vert-jaune
BKWH	schwarz-weiß	black-white	noir-blanc
GN	grün	green	vert
OG	orange	orange	orange
VT	violett	violet	violet
TQ	türkis	turquoise	turquoise

	Bedeutung der Kurzzeichen	Meaning of the symbols	Interprétation des symboles
B	Stecker	plug	fiche
C	Kondensator	condenser	condensateur
D	Funkentstördrossel	interference suppression inductance	inductance d'antiparasitage
E	Elektronik-Baustein	electronic unit	unité électronique
I	Induktionsspule	induction coil	bobine d'inductance
K	Klemme	terminal	borne
L	Licht	light	lumière
M	Motor	motor	moteur
O	Überlastschutz	overload cut-out	déclencheur de surintensité
R	Drehrichtungsumschalter	reversing switch	commutateur droite-gauche
S	Schalter	switch	interrupteur
U	Umschalter	change-over switch	commutateur
X	Elektronik-Element	electronic element	élément électronique